

DISTRIBUTION & COLLECTION SYSTEMS



BOTTOM HUB & STACK DIFFUSER MODELS

UKL offers molded distribution systems, designed to be adaptable for any make of FRP tank. Depending on the diameter of the tank, various sizes of laterals can be offered.

Our distribution systems have been manufactured using the best engineering materials to ensure maximum life of the product. UKL design team has ensured that these distribution systems are easy to assemble in the tanks and the uniform distribution and collection is ensured.

SALIENT FEATURES

- Suitable for any make of FRP tank
- Various lateral sizes available for different tank sizes
- Unique ¼ turn cam-lock hub and laterals make assembly and installation easy and secure
- Unique slot design assures a uniform, vertical distribution of flow and pressure drop <5psi at designated flow rates
- Temperature rating is 45 °C

STACK DIFFUSER FOR TOP/BOTTOM

for Tank Sizes 14" - 36"

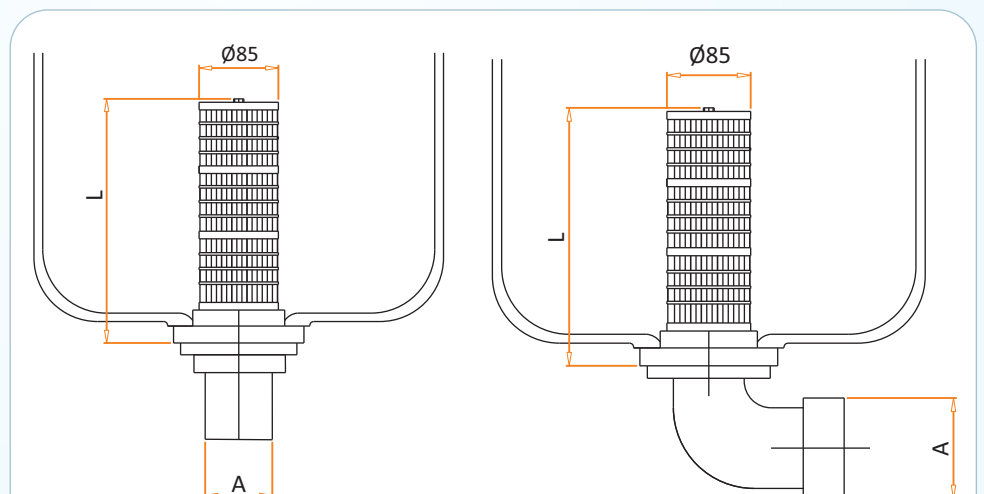
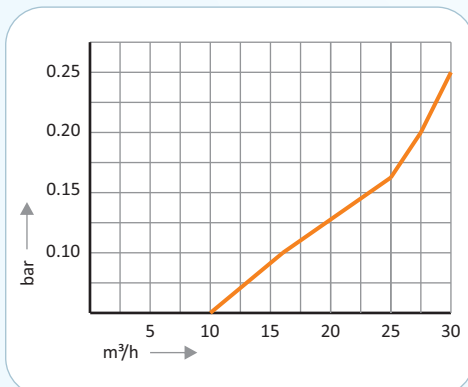

Type	Dimension (mm)		Tank Size Inches (mm)	Top Opening
	A	L		
D85	2" BSP (F)	175	14"-36"(350-900mm)	4"-8UN

TOP MOUNT DISTRIBUTOR 6 LATERALS - A SERIES

for Tank Sizes 14" - 36"

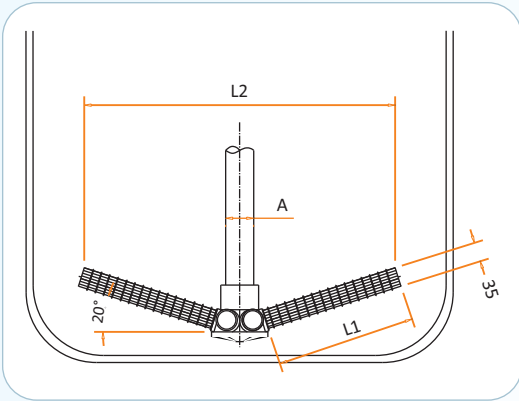
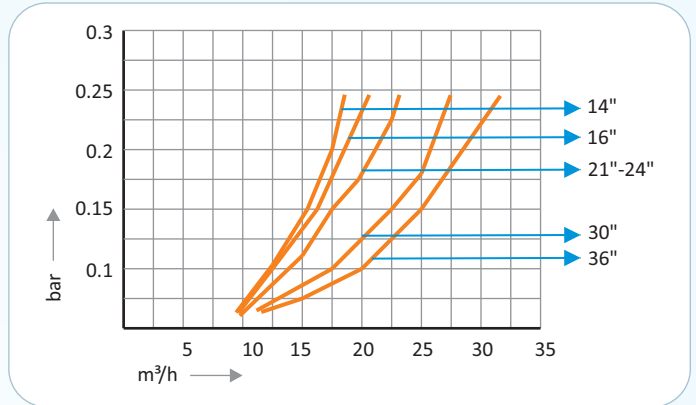

Type	Dimension (mm)			Tank Size Inches (mm)	Top Opening
	A	L1	L2		
A-0.25-6245	50	81	245	14"(350mm)	4"-8UN
A-0.25-6310	50	112	310	16"(400mm)	4"-8UN
A-0.25-6368	50	144	368	21"(550mm)	4"-8UN
A-0.25-6368	50	144	368	24"(600mm)	4"-8UN
A-0.25-6430	50	175	430	30"(750mm)	4"-8UN
A-0.25-6550	50	235	550	36"(900mm)	4"-8UN

SIDE MOUNT DISTRIBUTOR 6 LATERALS - A SERIES

for Tank Sizes 14" - 36"
with Elbow & Straight Connection

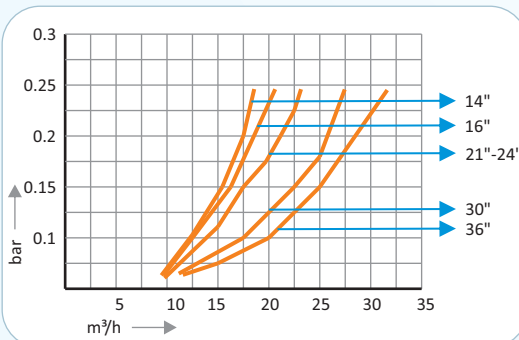
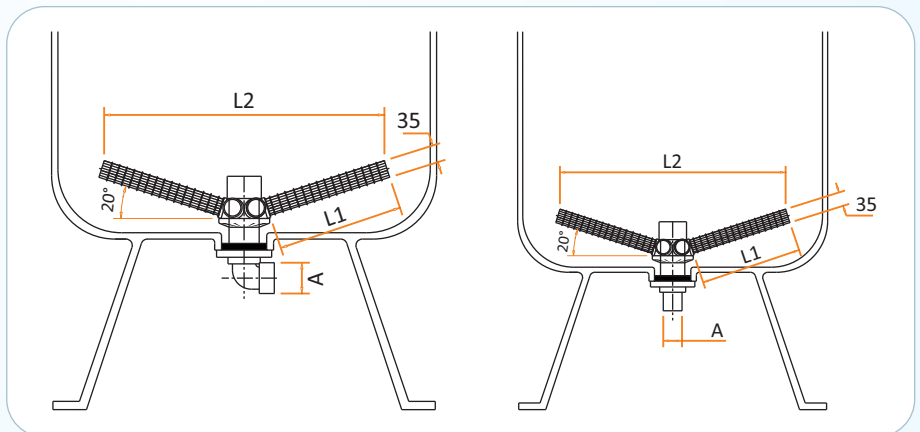

Type	Dimension (mm)			Tank Size Inches (mm)	Top Opening
	A	L1	L2		
A-0.25-6245	2" BSP (F)	81	245	14"(350mm)	4"-8UN
A-0.25-6310	2" BSP (F)	112	310	16"(400mm)	4"-8UN
A-0.25-6368	2" BSP (F)	144	368	21"(550mm)	4"-8UN
A-0.25-6368	2" BSP (F)	144	368	24"(600mm)	4"-8UN
A-0.25-6430	2" BSP (F)	175	430	30"(750mm)	4"-8UN
A-0.25-6550	2" BSP (F)	235	550	36"(900mm)	4"-8UN

SIDE MOUNT DISTRIBUTOR 6 LATERALS - B SERIES

for Tank Sizes 14" - 36"
with Elbow & Straight Connection

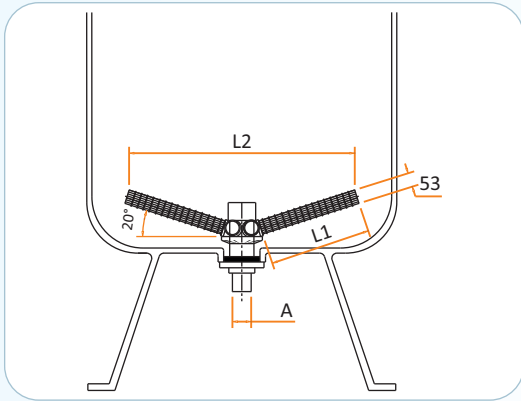
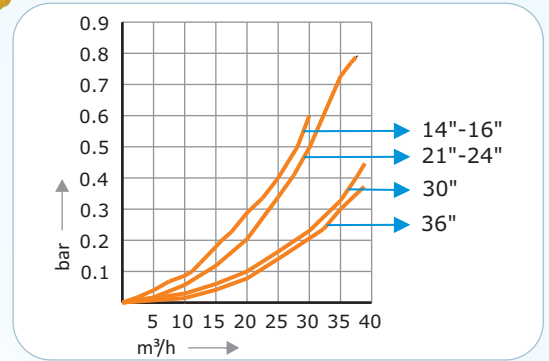

Type	Dimension (mm)			Tank Size Inches (mm)	Top Opening
	A	L1	L2		
B-0.25-6245	2" BSP (F)	81	245	14"(350mm)	4"-8UN
B-0.25-6310	2" BSP (F)	112	310	16"(400mm)	4"-8UN
B-0.25-6368	2" BSP (F)	144	368	21"(550mm)	4"-8UN
B-0.25-6368	2" BSP (F)	144	368	24"(600mm)	4"-8UN
B-0.25-6430	2" BSP (F)	175	430	30"(750mm)	4"-8UN
B-0.25-6550	2" BSP (F)	235	550	36"(900mm)	4"-8UN

SIDE MOUNT DISTRIBUTOR 6 LATERALS FOR FLANGES OPENING VESSELS

for Tank Sizes 16" - 36"

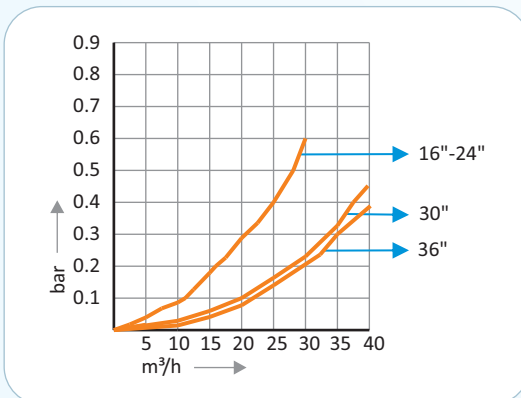
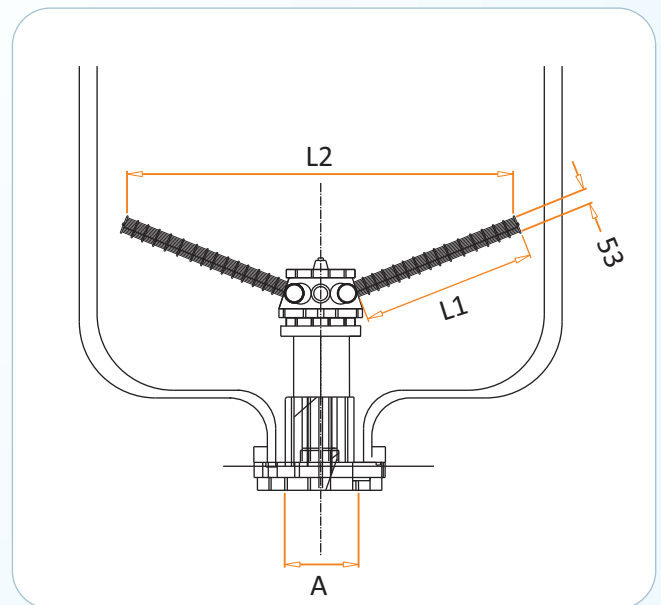

Type	Dimension (mm)			Tank Size Inches (mm)	Top Opening
	A	L1	L2		
B-0.25-6312	3" BSP (F)	118	312	16-24"(400-600mm)	6"FLG
B-0.25-6430	3" BSP (F)	175	430	30"(750mm)	6"FLG
B-0.25-6550	3" BSP (F)	235	550	36"(900mm)	6"FLG

SIDE MOUNT DISTRIBUTOR 8 LATERALS

for Tank Sizes 42" - 63"

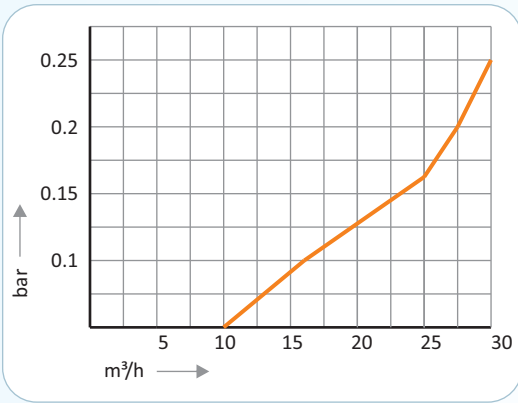
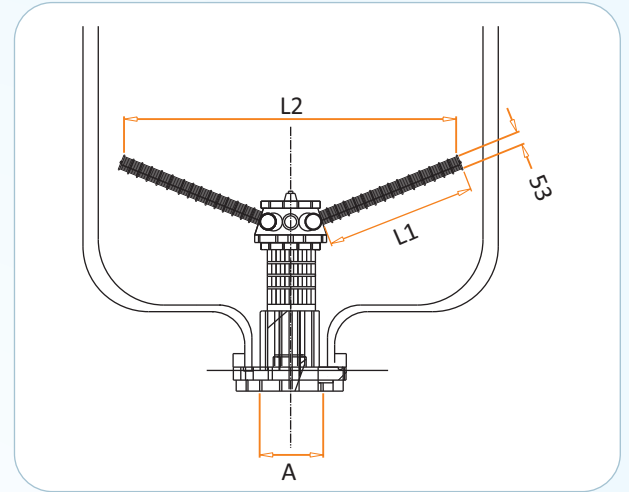

Type	Dimension (mm)			Tank Size Inches (mm)	Top Opening
	A	L1	L2		
B-0.25-8805	3" BSP (F)	360	805	42"(1050mm)	6" FLG
B-0.25-8920	3" BSP (F)	415	920	48"(1200mm)	6" FLG
B-0.25-81035	3" BSP (F)	470	1035	60"(1500mm)	6" FLG
B-0.25-81165	3" BSP (F)	545	1165	63-80"(1600-2000mm)	6" FLG

SIDE MOUNT DISTRIBUTOR 16 LATERALS

for Tank Sizes 42" - 48"

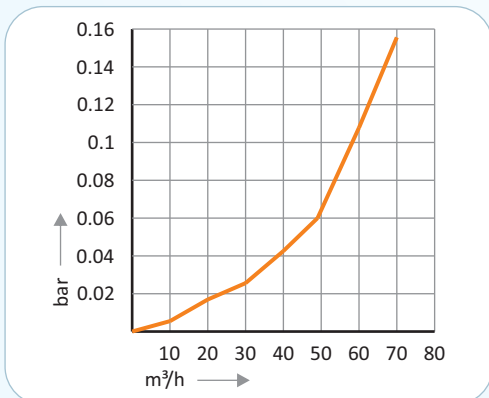
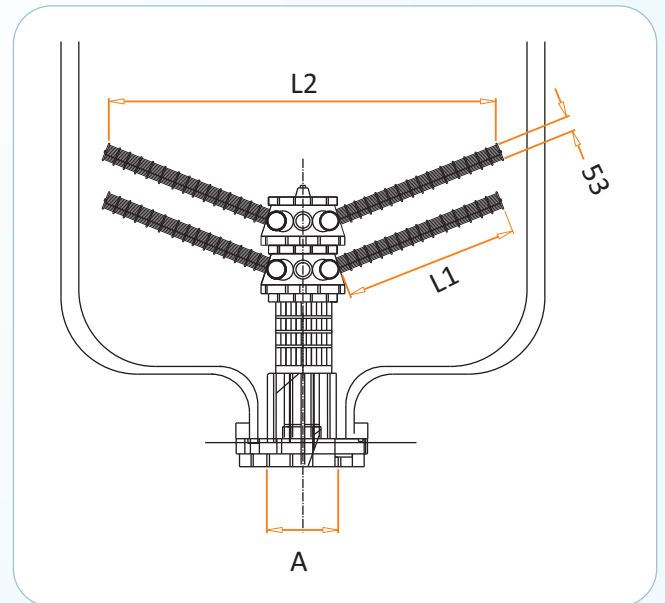

Type	Dimension (mm)			Tank Size Inches (mm)	Top Opening
	A	L1	L2		
B-0.25-8805-2	3" BSP (F)	360	805	42"(1050mm)	6" FLG
B-0.25-8920-2	3" BSP (F)	415	920	48"(1200mm)	6" FLG

SIDE MOUNT DISTRIBUTOR 16 LATERALS

for Tank Sizes 63" - 80"

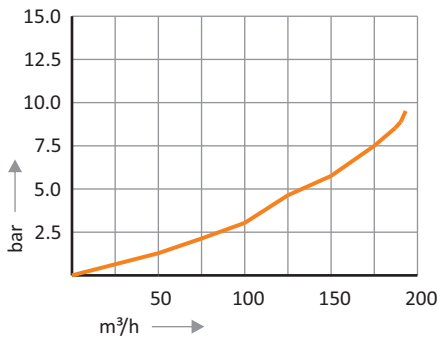
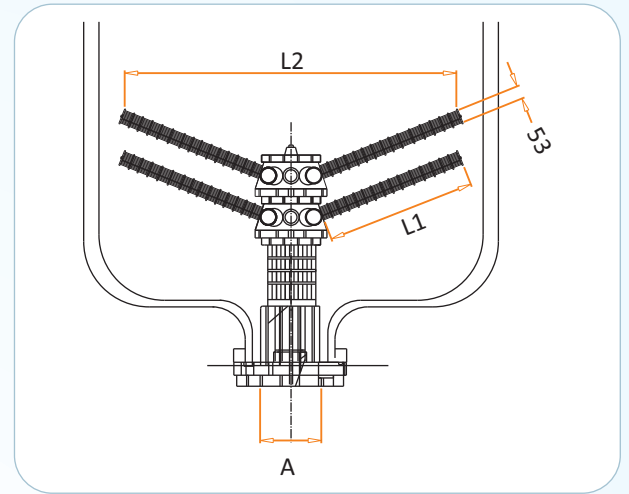

Type	Dimension (mm)			Tank Size Inches (mm)	Top Opening
	A	L1	L2		
B-0.25-81035-2	3" BSP (F)	470	1035	60"(1500mm)	6"FLG
B-0.25-81165-2	3" BSP (F)	545	1165	63-80"(1600-2000mm)	6"FLG

STACK DIFFUSER FOR TOP/BOTTOM FLANGED OPENING VESSELS

for Tank Sizes 24" - 48"

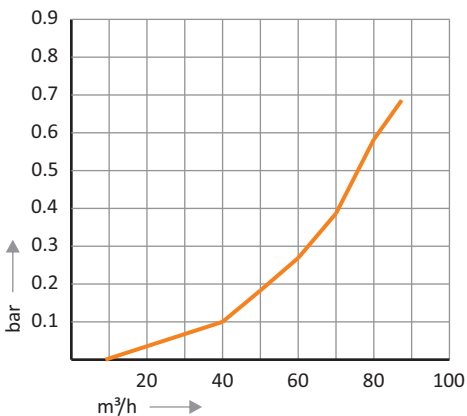
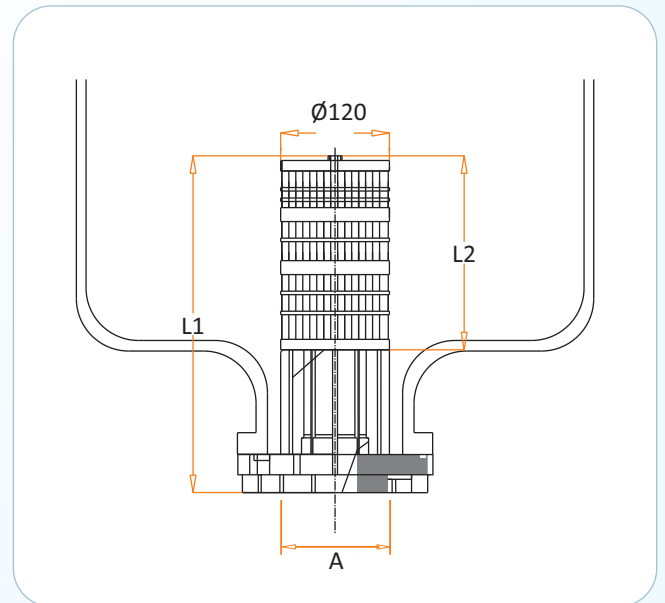

Type	Dimension (mm)			Tank Size Inches (mm)	Top Opening
	A	L1	L2		
D120	3" BSP (F)	375	260	24-48"(600-1200mm)	6"FLG

FILTER NOZZLES

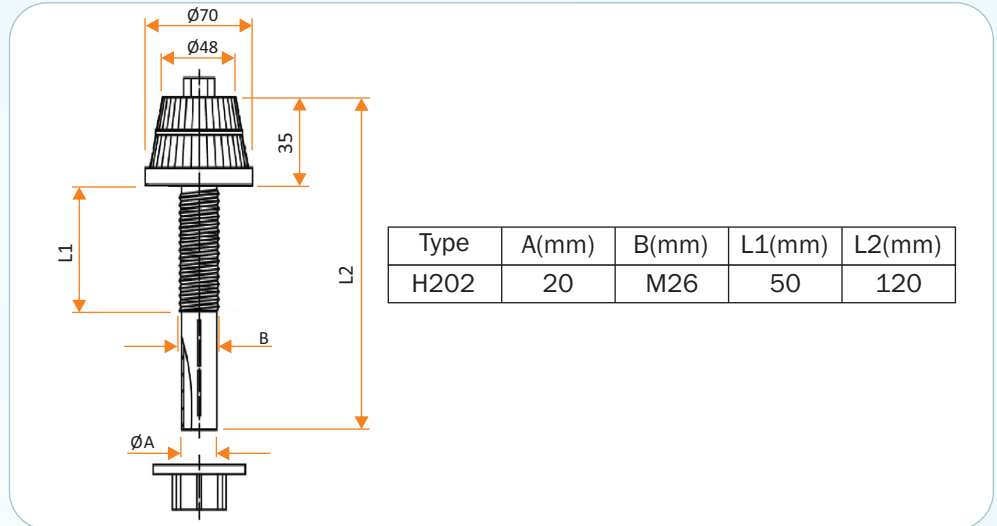

VACUUM BREAKER

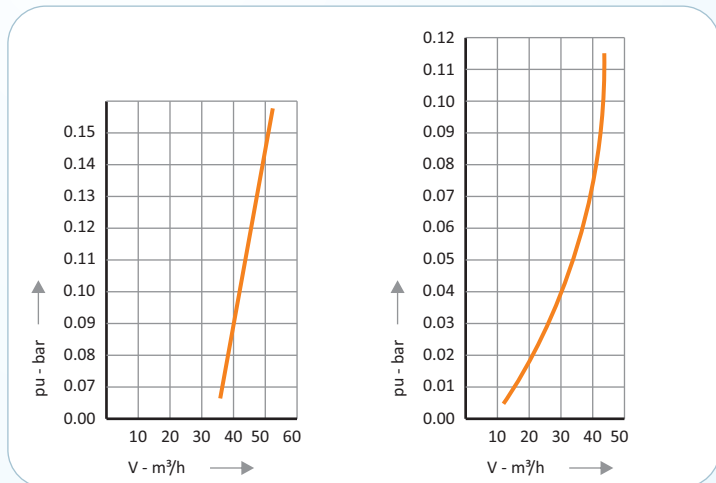
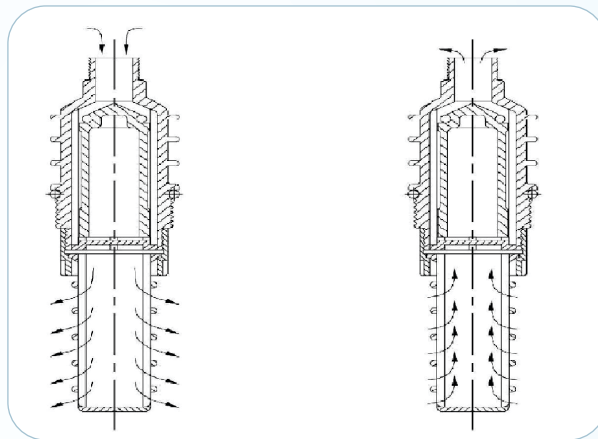
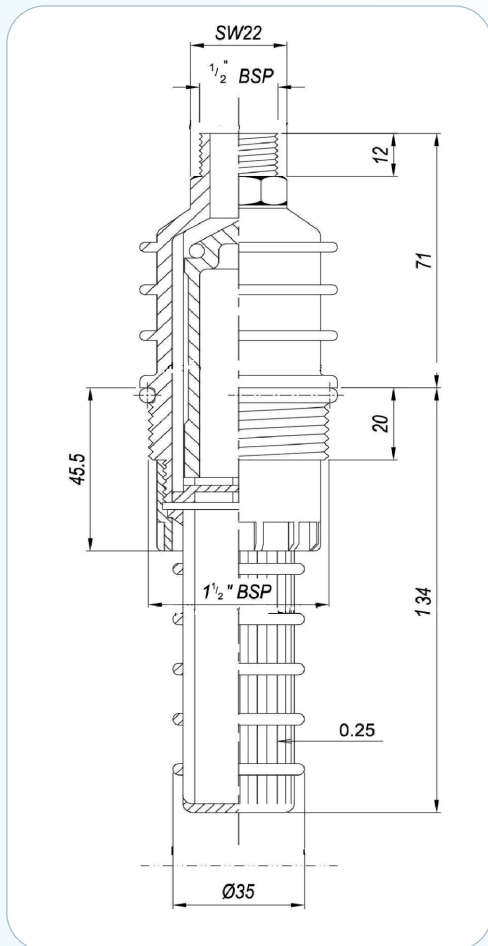

UKL Instruments Pvt. Ltd.

📍 232, 7th Street, Ashtalakshmi Nagar, Alapakkam, Chennai - 600 116.

☎ 98411 27656, 94440 80171

✉ shreeram@uklindia.in

🌐 www.uklindia.com

